

# Panorama VR-System Mini

N  
NOVOFLEX

MANUAL

Congratulations! By purchasing your **Panorama VR-System Mini** you have acquired a tool, which enables you - together with a compact DSLR- or mirrorless system camera, a tripod, a ballhead and a personal computer - to generate high quality panoramas simply.

To achieve exceptionally good results, you should make some adjustments before taking your pictures. These instructions will help familiarize you with the most important working steps.



## Which equipment is necessary?

Beside your **Panorama VR-System Mini**, consisting of panorama base **Panorama=Q 48** (1), clamping plate with quick release **QPL Slim 200** (2), angle bracket **QPL Slim Vertikal** (3) and **Spirit Level** (4) for the flash shoe, you will require:

- A digital camera (ideally a compact DSLR or mirrorless system camera with a standard or wide angle lens)
- A stable tripod (recommended: Novoflex **Triopod**)
- A ball head or leveling base (recommended: Novoflex **MagicBalance**)
- A PC (ideally a current computer with a lot of ram and a large hard disk) and a panorama software (recommended: **PanoramaStudio** or **PTGui**)

© NOVOFLEX Präzisionstechnik GmbH  
Brahmsstraße 7, D - 87700 Memmingen  
Phone +49 8331 88888, Fax +49 8331 47174  
mail@novoflex.com, www.novoflex.com

N  
NOVOFLEX

Text and photo material: Jan Röpenack

## How is the panorama created?

Using the stitching technique, the final panorama will be an assembly of a series of individual images. Between these single shots the camera will be rotated around a certain angle. You create your panorama afterwards on the computer using a stitching software e.g. *PanoramaStudio* or *PTGui*.

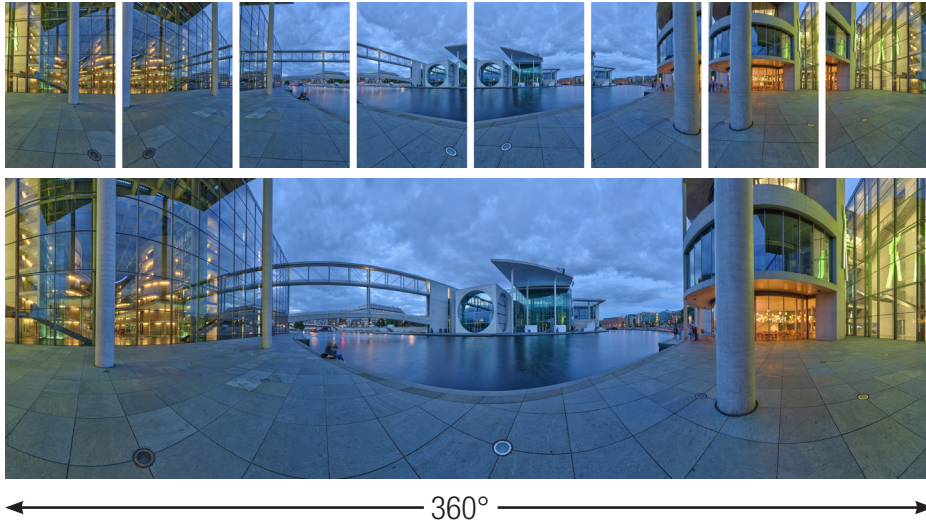

Example above: Taken with a fullframe camera and a 17mm wide angle lens, panning angle 45° (increment selector lever at 16 on the panorama base *Panorama=Q 48* and taken at every second click-stop). Details about the right panning angle, click-stops and the increment selector lever starting at page 10 in this manual. The stitching to a 360° cylindrical panorama was done afterwards using the software *PanoramaStudio*.

## Why should I use a panoramic tripod head?

The panoramic tripod head (your *VR-System Mini*) makes it possible to rotate the entire optical system around the centre of the entrance pupil of the lens, also called the “nodal point”, “optical center” or “no parallax point”. Thereby parallax effects are avoided, which is very important for the subsequent composition of the single frames. Only this way can the stitching software work accurately and give you the best possible results.

## Step 7:

### Taking the pictures:



120° Cylindrical Panorama: Taken with a fullframe camera and 35mm wide angle lens, panning angle 22,5° (increment selector lever at 16 on the panning base *Panorama=Q 48*), Software *PanoramaStudio*.



180° Cylindrical Panorama: Taken with a fullframe camera and 28mm wide angle lens, panning angle 30° (increment selector lever at 36 on the panning base *Panorama=Q 48* and taken at every third click-stop), Software *PTGui*.

## Step 6:

### Camera settings:

- For best quality, standardize the exposure in each single frame, meaning choose manual exposure mode. When it is not possible, because the intensity of light varies between the single exposures strongly, consider the HDR technique using autobracketing with your camera.
- The optimal f-stop is located between f8 and f11. In this range you have enough depth of field and fewer problems with vignetting of the lens (dark corners).
- Place the focus on the main subject of the scene. Then turn off the auto focus system.
- Use a fixed white balance such as sunny, cloudy etc. (don't use automatic white balance, otherwise you will have frames with different colors). When taking the pictures in RAW format you can match the white-balance afterwards also. Please take care, that all shots belonging to one panorama have to be processed the same way.
- In the case of longer exposure time, we recommend using a remote release and - if possible - the mirror lockup or live-view function of your camera. Please refer to your cameras manual. Also useful - as an alternative - is the selftimer with two seconds forerun. Please use the angle locking screw in such situations.

### Last checkup:

- System leveled to the horizon (verify with the spirit level on the panning base)?
- Set panning angle (increment), depending on the focal length?
- Correct values on the scales?
- Set fixed white balance (e.g. sunny)?
- Manual exposure mode?
- Correct exposure (f-stop in the middle range, corresponding exposure time)?
- Focused on the main subject of the scene?
- Auto focus system turned off?



Wrong: *Turn to the right without panorama head*

The foreground (flower) moves to the left towards the background (mountain). This will cause problems when assembling the panorama.



Right: *Turn to the right with panorama head*

The foreground (flower) stays properly positioned with the background (mountain). This is the requirement for accurate stitching of the panorama.

## Basic assembly:

In the next chapter you will find the position of the entrance pupil of all your lenses. You should write these carefully determined values down on a list for future exposures with these lenses. In order to be sure that your values are reproducible you should assemble your *VR-System Mini* always in the same way.

### Connecting the panning base *Panorama=Q 48* to a tripod, ballhead, tripod head or leveling device

Connect the panning base *Panorama=Q 48* (1) to your tripod, ballhead, tripod head or leveling device, using the center 3/8" drilling hole. The silver-colored insert is an adapter to the smaller 1/4" thread, which can be removed if needed.

The panning base has an additional headless screw for an anti-twist assembly. In order to use this screw, turn the base in the 0° angle position and use the small Allen key (in the scope of delivery) by inserting it from above in the hole near the spirit level. By turning the Allen key in a clockwise direction, the headless screw will be pressed against the device mounted below. In this way, the base gets stuck on the device and will not disassemble when doing a left panning in front of the scene.

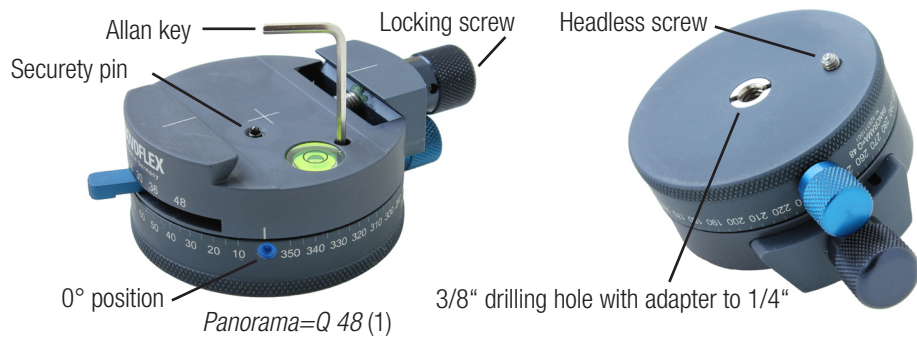

**Advice:**

Please keep in mind, that the use of the headless screw can damage the device below the panning base a little. Therefore do not tighten the headless screw too much. When dismantling the base afterwards, you have to unloose the headless screw first!

The panning base *Panorama=Q 48* (fig. 1 above) has a security pin, to prevent inadvertent dropping of the equipment when the locking screw is not completely tightened. This pin grabs into the milling groove on the backside of the clamping plates typ Q. (fig. 2 below). This security mechanism can be used at the same time for reproducible positioning of the clamping plate *QPL-Slim 200* on the panning base.



(2) Backside of the clamping plate *QPL-Slim 200*

**QPL Slim 200 assembly**

Our aim is to position the pivot point into the optical center of the lens. Therefore a certain distance must be set up with the help of the clamping plate. This can be done in two ways:

**Method A:** The quick release has a fixed position on the plate (2) and moving the clamping plate *QPL Slim 200* on the panning base (1).

**Method B:** The clamping plate (2) has a fixed position on the panning base (1) and moving the quick release on the clamping plate (2).

On the other hand, if you want to create telephoto panoramas with a limited field of view and using long focal lengths, I suggest mounting the camera in **landscape mode**. The advantages are larger increments, what makes the adjustment on the panorama base much easier.

By the way, the position of the nodal point will not alter when changing the method of mounting.



**LANDSCAPE MODE**

**Recommended increment and adjustment at lever**

focal length full-frame sensor	focal length sensor APS-C size	increment in °	exposures per 360° turn n	adjustment at lever
70-100 mm	45-63 mm	15	24	48 (2 clicks)
101-150 mm	64-94 mm	10	36	36 (1 click)
151-220 mm	95-138 mm	7,5	48	48 (1 click)

**Tip:**

Don't take large charts with you, when you go out for taking pictures, but narrow them down to the information you really need on location. That is the nodal point distance and the increments of your favorite lenses. It is very useful to write down this information on a little label and fix it to the angle bracket or tripod.

You can see my personal label in the illustration on the right.

**Please notice:** My label only applies for my personal camera-lens-combination, based on my experience and is not transferable in general. By the way, I mount my camera only in portrait mode, using a 16-35mm zoom and 50mm prime lens on a fullframe camera.

f. length	Lever
16-21	8 (16/2)
22-25	10 (30/3)
26-30	12 (36/3)
31-35	15 (30/2)
50	18 (36/2)
Nodalpt.	cm
16-35	10,9
50	4,2

*My personal label*

**Step 5:**

**Set up the nodal point:**

Adjust the distance between the rotating axis and the camera with the clamping plate (method A) or quick release (method B), depending on the lens you are using. Reuse the settings you've found before (see chapter *"Finding the nodal point", preparatory step 5*).

The tables in this manual are based on an overlap of 20-50% between two single shots and shows the recommended adjustment of the increment selector lever as a function of the camera (full-frame or APS-C sensor size) and the focal length of the lens in mm.

**Example:** You are using a full-frame camera and a 28 mm lens (corresponds roughly to a camera with APS-C sensor size and 18 mm lens). According to the table you set up the value 36 with the lever and take the pictures at every third click-stop.

**Tip:**

The specialty of panoramic photography is the unique opportunity, to display extremely wide angles of view, even 360°, which is impossible with an ordinary camera.

The horizontal field of view of your completed panorama is specified by the number of pictures you take. The vertical field of view is dependent only on the focal length of the lens used. If you want a panorama with a field of view as large as possible, mount the camera in **portrait mode** while using a short focal length. In other words, use a wide angle lens vertically. The portrait mode is the most common way to mount the camera when taking panorama shots. Ideal for wide angles of view (e.g. 360° panorama) using short or medium focal length lenses.

Portrait Mode



Landscape Mode



More ideal is **Method A**, because you can leave the quick release in a fixed position at the plates rear edge, having full access to the locking screw from behind. Moreover, scale values on the clamping plate can be read off from above very easily. Only when using a strong wide angle lens, seeing the clamping plate within the viewfinder, you should position the quick release more forward or switch to Method B.

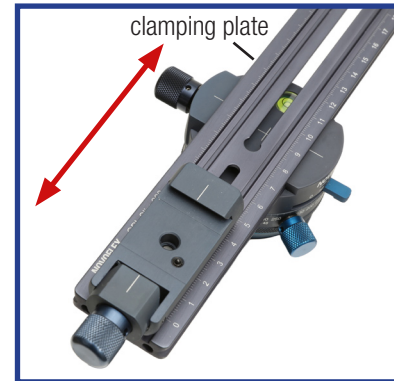

**Method A:** Move the complete plate including the fixed quick release.

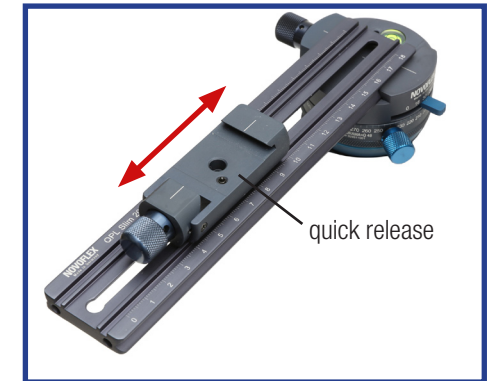

**Method B:** Move only the quick release on the clamping plate.

**Set up using Method A**

Open the silver-colored screw belonging to the quick release at the backside of the clamping plate (fig. 2 left opposite) and position the quick release precisely in line with the plates rear edge, using the big Allen key in the scope of delivery. In order to set up reproducible distances later, you should not change the quick release position at the plate from now on.

**Set up using Method B (as an alternative)**

Move the quick release on a freely chosen position on the clamping plate as described using Method A. The exact position will be determined later on. Open the grey locking screw on the panning base (1) completely and insert the clamping plate (2) centered. Tighten the grey screw on the panning base. Now open the locking screw again but only a half turn. Slide the clamping plate within the base backwards as far as possible. The security pin will stop this movement at scale value 18. This is where you tighten the locking screw on the panning base. In order to set up reproducible distances later, you should always use this method to assemble your device in front of the scene.

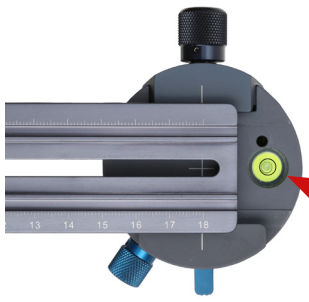

Set up using method B:  
Reproducible assembly with the help of the security pin. The scale value is showing 18 on the clamping plate. The spirit level can be seen from above very well.

When leveling the system observe the spirit level on the panning base. You can see the level even through the plates slot.

## Preparatory Steps:

### Finding the nodal point:

The position of the nodal point (also called “optical center”, “no parallax point” or “entrance pupil”) is dependent on the camera-lens-combination and - when using a zoom lens - on the focal length you use. Therefore you should try to find the position of the nodal point of all lenses that you will use and write them down. For this use the engraved scales on the plate and angle bracket. When taking the pictures later, you only have to transfer the values before you start shooting.

### Preparatory step 1:

**Assemble all components of your system, beginning from the top down:**

- Spirit level on the flash shoe
- Camera with lens
- Angle bracket *QPL Slim Vertikal*
- Clamping plate *QPL Slim 200*
- Panning base *Panorama=Q 48*
- Tripod head or leveling device
- Tripod

### Preparatory step 2:

**Level your panoramic head with the horizon:**

Watch the spirit level on your panning base *Panorama=Q 48* (fig. above) and level the system by the ball head or leveling device beneath.



The numbers of shots for a complete 360° turn can be selected directly at the **Increment Selector Lever**. Between two shot, just turn the system to the next click-stop. Using the blue **Angle Locking Screw** you can fix the current angle position if needed, e.g. to maximize the stability. Before going to the next click-stop, untighten the screw by all means!

### More increments by counting the “clicks”

When taking the pictures not at any snap in, but at every second, third or fourth “click-stop”, you have notable more selectable increments available. Here’s an example: The increment of  $n=8$  (45°) can be achieved by selecting  $n=16$  (22,5°) with the increment selector lever and taking the pictures at every second stop.



## PORTRAIT MODE

### Recommended increment and adjustment at lever

focal length full-frame sensor	focal length sensor APS-C size	increment in °	exposures per 360° turn n	adjustment at lever
Fisheye 8-12 mm	Fisheye 4-7 mm	90	4	16 (4 clicks)
Fisheye 13-16 mm	Fisheye 8-10 mm	60	6	30 (5 clicks)
14-21 mm	8-14 mm	45	8	16 (2 clicks)
22-25 mm	15-16 mm	36	10	30 (3 clicks)
26-30 mm	17-19 mm	30	12	36 (3 clicks)
31-34 mm	20-22 mm	24	15	30 (2 clicks)
35-44 mm	23-28 mm	22.5	16	16 (1 click)
45-54 mm	29-34 mm	20	18	36 (2 clicks)
55-65 mm	35-41 mm	15	24	48 (2 clicks)
66-89 mm	42-56 mm	12	30	30 (1 click)
90-105 mm	57-66 mm	10	36	36 (1 click)
106-160 mm	67-100 mm	7.5	48	48 (1 click)

Although your *Panorama=Q 48* panning base has only 4 selectable increments (due to small dimensions and low weight) you can use all required increments by counting the clicks up to a focal length of 220 mm (on full-frame camera).

## Field use:

### Step 1:

#### Transport:

Common practice is to transport the equipment in two parts:

- Part 1: Tripod with mounted ball head, with the panning base and clamping plate
- Part 2: Angle bracket with mounted camera and spirit level on the flash shoe

When you have performed *preparatory steps 1 to 5* in the chapter *“Finding the nodal point”* before, only a few steps are necessary to start exposing:

### Step 2:

#### Level your panoramic head with the horizon:

Closely watch the spirit level of your panning base *Panorama=Q 48* and level the system with the ball head or leveling device beneath. You don't have to align the tripod.

### Step 3:

#### Fix the angle bracket with mounted camera on the focusing rack:

Use the angle brackets indicator scale and values you have found before (see chapter *“Finding the nodal point”*, *preparatory step 4*)

### Step 4:

#### Define the panning angle “increment“:

Between the single exposures you rotate the system with the panorama plate around a specific angle. This angle depends on the wanted overlap, the camera you use (crop factor), the focal length and the method of mounting the camera - landscape or portrait (tip: portrait for wide angle photography, landscape when using telephoto lenses).

For optimal performance the software needs an overlap of 20-50%. Between each exposure use a fixed panning angle. To estimate the increments, look through the viewfinder while panning your system through the scene. It's much easier to orientate yourself with the charts in the following.

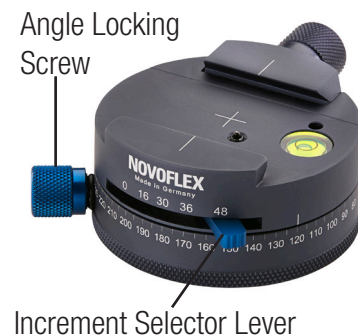

### Preparatory step 3:

#### Bring the camera to a precise vertical position:

Observe the spirit level on the flash shoe of your camera and use the screw, that connects the camera body with the angle bracket, for adjusting. For this purpose you need a coin or the big Allen key. When looking through the viewfinder, the AF point in the middle is now at the horizon.

### Tip:

If you do not remove the camera from the angle bracket for transport, you don't have to do this step again when taking your actual shots later. When setting up the right position, make sure that you have access to the battery- and memory card slot.

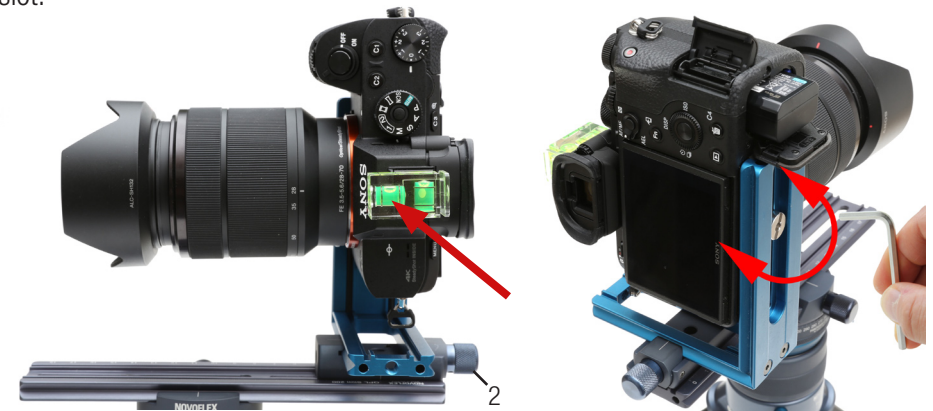

### Preparatory step 4:

#### Side-to-side adjustment: Move the camera into the pivot axis of the tripod head

Unlock the grey screw on the plates quick release (2, fig. above) a bit and shift the angle bracket (3, fig. right) until the center of the lens is directly over the pivot axis of the panoramic head. To do this, move to the front of the panoramic head so you're looking into the lens. For exact adjustment you can use a ruler, a pendulum or a second angle bracket. Afterwards lock the grey screw (2) again.

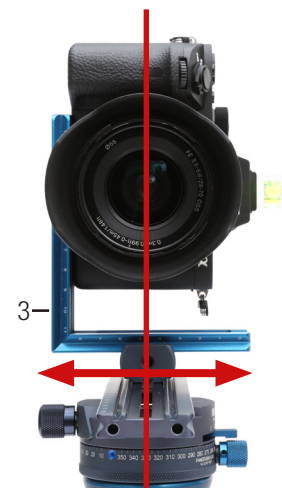

**Tip:**

The angle bracket has an engraved indicator scale on its side in order to set up the right value again in front of the scene. Write down the value you have just found.

**Preparatory step 5:**

**Forward-Backward Adjustment:**

Mount the lens, whose nodal point you want to find, to the camera body. When using a zoom lens, set the required focal length.

Look through the viewfinder. Find a vertical edge or line, such as a floor lamp, which is located in the foreground and bring it in line with a vertical object in the background e.g. a door frame or an edge of a building. You may have to move the tripod for this purpose. Now pan the camera from right to left and back while looking through the viewfinder. When the two vertical lines move to each other (see fig. 1+2), you are outside the nodal point. When they stay together (see fig. 3+4), you are inside the nodal point.

In this example I brought the floor lamp in line with the door frame (fig. 1). When I panned the camera to right, the floor lamp moved to left in relation to the door frame (fig. 2). This is an indication of rotating outside the nodal point of the lens.

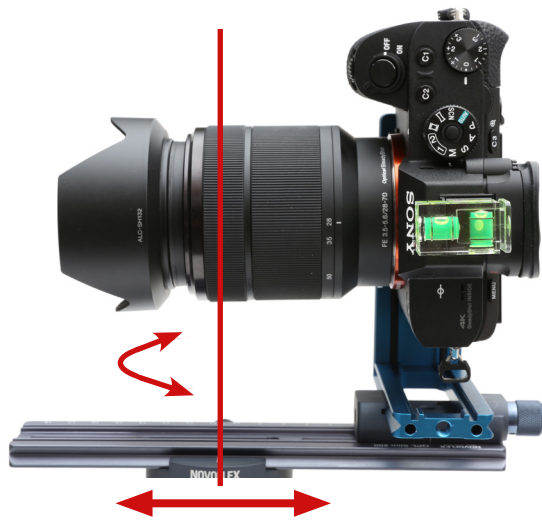

fig. 1



fig. 2



fig. 3



fig. 4

**Advice:**

If your camera is equipped with a depth of field preview, use it while you are looking through the viewfinder and close the aperture, so that you have the maximum depth of field.

Now set another distance on the plate. When panning again you will notice that the movement of the lines to each other will either be stronger or weaker. In the last case you shifted the plate in the right direction. Repeat the procedure until the vertical lines stay side by side (see fig. 3+4).

Now the whole system is panning in the nodal point of the lens.

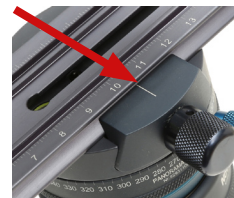

Write down these settings for future exposures with this camera-lens-unit. For this purpose read off the values given by the indicator scale on the plate.

When shifting the quick release instead of the plate (set up using method B) use the indicator mark on the quick release.

